



Q8/B8 SERIES

Combustible Gas Transmitter



The Q8/B8 Series of Explosion Proof Gas Detectors are used in applications that require a rugged enclosure that meets the Class 1 Division 1 requirements. Each unit comes standard with an integral clock, digital display of concentration, relay status, STEL, TWA, and peak daily values of the gas being detected. A three color backlight will flash depending on the level of alarm for operator safety. Setup and calibration is accomplished through non-intrusive magnetic switches that allow for programming of all parameters. A remote sensor option is available for toxic and combustible gases and should be used in applications where the main unit can be mounted at 3 to 6 feet off of the floor with the remote sensor being at the ceiling or floor levels to monitor

the gas concentrations depending on the gas being monitored. Sensor types include electrochemical and catalytic bead sensors to meet the demand and performance requirements for particular industries. The Q8 uses Optomux and Modbus RS-485 protocol, 4-20 mA, 1-5 or 2-10 VDC while the B8 uses BACnet™ MSTP(RS485) protocol to communicate directly with a BAS. The Q8/B8 also has three (3) SPDT Form 1C relays that are user adjustable. Refer to all applicable Federal, State, Provincial and Local Health and Safety laws and regulations before using these products. The Q8/B8-GENL can be ordered to monitor specific combustible gases such as Gasoline, Ethanol, Diesel or Jet fuel. Contact ACI for specific gases.

Applications: Mechanical Rooms, Warehouses, Refrigeration Plants, Industrial Plants, Process Monitoring, Leak Detection, Parking Garages, Auto/Truck Maintenance Facilities, Oil and Gas Industry

The Q8/B8 Series Gas Transmitters are covered by ACI's Two (2) Year Limited Warranty against defects in material and workmanship from the date of shipment with the exception of the Sensor Modules (Electrochemical/Toxic: Six Months and Catalytic/Combustible: One Year). The warranty can be found in the front of ACI's Sensors & Transmitters catalog, as well as on ACI's website, workaci.com.

PRODUCT SPECIFICATIONS

Supply Voltage [Q8]:	VDC Supply Voltage: 24 VDC nominal (+18 to 30 VDC) VAC Supply Voltage: 24 VAC nominal (+15 to 24 VAC, AC Power must not be grounded)
Supply Voltage [B8]:	VDC Supply Voltage: 24 VDC nominal (+18 to 30 VDC) VAC Supply Voltage: 24 VAC (+15 to 24 VAC, AC power can be grounded or non-grounded)
Fuse Protection:	0.750A Polyswitch; (Automatically resets after fault is cleared & power to circuit is removed)
Supply Current Power Consumption:	0.3A maximum 8.4 VA
Analog Output Signals (Q8 Only):	4-20 mA, 1-5 VDC or 2-10 VDC (4-Wire Power, Power Ground, Output Signal, Output Signal Common)
Load Impedance:	4-20 mA Output: 600 Ohms maximum 1-5 VDC or 2-10 VDC: 3000 Ohms minimum
Communication Protocols:	Q8 Communication Protocols: RS-485 Modbus RT/OptoMux (Proprietary QEL Communication) B8 Communication Protocols: RS-485 Serial BACnet™ MS/TP (Master and Slave; Default: Master)
Q8 Communication Baud Rates:	1200, 2400, 4800, 9600, 14400, 19200, 28800, 38400, 57600, 76800 Bits/Second (Default: 4800)
B8 Communication Baud Rates:	9600, 19200, 38400, 76800 Bits/Second (Default: 38400)
Factory Calibration Range:	See Gas Sensor Selection & Specification Table on back of data sheet
Display:	LCD Graphic Display with backlight (Displays TWA, STEL and PEAK Daily Value)
Keypad:	Three (Non-Intrusive) Magnetic Switches
Relays Contact Type Relay Contact Ratings:	Three, SPDT (Form 1C) Dry Contact rated 1.0A max. @ 30 VDC or 0.3A max. @ 125 VAC (Resistive Load)
Status LEDs:	Two Green LED's (Tx/Rx Communication Status), Three Red LED's (Relays 1, 2 & 3 Status)
Factory Calibrated Range:	See Gas Sensor Selection & Specification Table on back of data sheet
Sensor Warm-Up Time:	24 Hours (Allow 24 hours before calibrating sensor after initial installation)
Sensor Type:	See Sensor Technology Type in Table on back of Product Data Sheet
Gas Type:	Combustible and Toxic Gases/Oxygen Sensor Electrochemical (Toxic): 2 to 3 Years, typical Oxygen/Hydrogen (Toxic): 18 months, typical Catalytic (Combustible): 3 to 5 years, typical Infrared: > 5 years
Life Expectancy:	
Unit Shelf Life:	Electrochemical (Toxic): 6 Months from date of purchase (Must be installed and operational) Catalytic (Combustible): 1 Year from date of purchase (Must be installed and operational)
Replacement Sensor:	See User's Manual or Contact ACI Catalytic (Combustible): Accuracy & Bump test every 3 months or as required by Code
Recommended Maintenance:	Electrochemical (Toxic): Accuracy & Bump test every 6 months or as required by Code Oxygen/Hydrogen (Toxic): Calibrate every 3 months
Enclosure Specifications (Type, Material Type, Flammability, NEMA/IP Rating, Explosion Proof):	Industrial Connection Head; Cast Aluminum Epoxy Coated NEMA 4X (IP66), Division 1 Division 2, ANSI/ISA 12.22.01 Class I, Zone 1, AEx d II C, IP66 Zone 1 CSA E60079-1 Ex d II C, Class I, Zone I, IP 66 CSA C22.2 No. 30 Class I, Groups A, B, C, D; Class II Groups E, F, G; Class III





PRODUCT SPECIFICATIONS

Operating environment:	Indoor Use Only
Conduit Connector:	Two 3/4" NPT Threaded Openings
Operating Temperature Humidity:	See Sensor Selection & Specification Table on back of data sheet 5 to 95% RH, non-condensing
Operating Atmospheric Pressure¹:	14.696 psi (1.0132 bar) +/- 10%
Recommended Storage Temperature Humidity:	32 to 68°F (0 to 20°C) 5 to 95% RH, non-condensing
Wiring Connections Wire Size:	Depluggable Screw Terminal Blocks 16 to 24 AWG (0.51 to 1.30 mm) Shielded Twisted Pair
Communication Cable:	Belden 9841 or Equivalent, 120 Ohms Input Impedance
Terminal Block Torque Rating:	0.37 ft-lb (0.502 Nm) Nominal
Coverage Area Mounting Height:	See Gas Sensor Selection & Specification Table on back of data sheet
Approvals:	RoHS, CSA-Class 4828-02 inspected to C22.2 No. 30 and No. 142 (CSA File #: 088890_0_000)
Product Weight:	4.35 lbs. (1.973 kg)
Product Dimensions (L x W x H):	7.48" (190 mm) x 5.71" (145 mm) x 5.12" (130 mm)

Note¹: When installed @ >3000' above sea level, the gas transmitters must be verified for accuracy & re-calibrated as needed after installation

DIMENSIONAL DRAWING

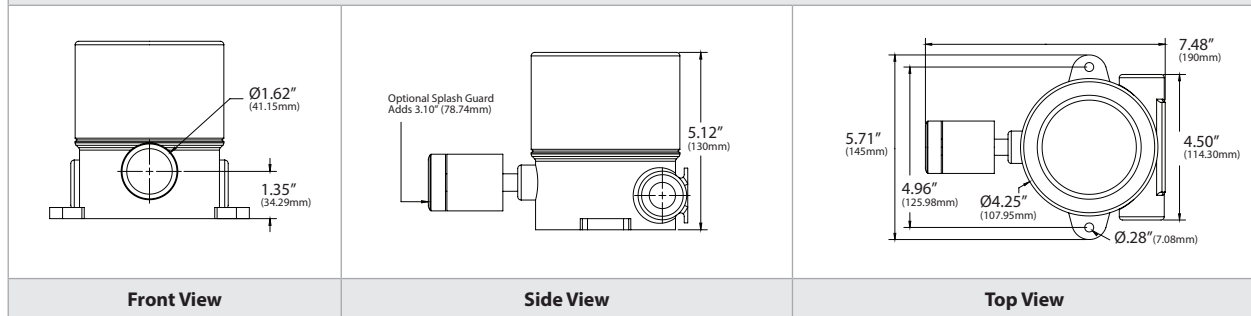



SENSOR SELECTION AND SPECIFICATION

Gas Type	Gas Span Code	Combustible	Toxic	100% LEL ¹ in % By Vol.	Measurement Range	Operating Temp °F (°C)	Square Feet ft ² (m ²)	Radius ft (m)	Mounting Height
Acetone	CH3CO-100L	•		2.6%	0-100% LEL	14 to 122 (-10 to 50)	5000 (464.5)	40 (12.2)	Low ²
Ammonia	NH3-100P		•	N/A	0-100 PPM	-22 to 122 (-30 to 50)	7500 (696.7)	49 (14.9)	High ²
Ammonia	NH3-1000P		•	N/A	0-1000 PPM	-22 to 122 (-30 to 50)	7500 (696.7)	49 (14.9)	High ²
Arsine	ASH3-1P		•	N/A	0-1 PPM	-4 to 104 (-20 to 40)	5000 (464.5)	40 (12.2)	Low ²
Benzene	C6H6-100L	•		1.3%	0-100% LEL	14 to 122 (-10 to 50)	5000 (464.5)	40 (12.2)	Low ²
Iso-Butane	C4H10-100L	•		1.8%	0-100% LEL	14 to 122 (-10 to 50)	5000 (464.5)	40 (12.2)	Low ²
Butanol, n-Butane	BUTAN-100L	•		1.9%	0-100% LEL	14 to 122 (-10 to 50)	5000 (464.5)	40 (12.2)	Low ²
Carbon Monoxide	CO-250P		•	N/A	0-250 PPM	-4 to 122 (-20 to 50)	7500 (696.7)	49 (14.9)	Mid ²
Carbon Monoxide	CO-1000P		•	N/A	0-1000 PPM	-4 to 122 (-20 to 50)	7500 (696.7)	49 (14.9)	Mid ²
Carbon Dioxide	ICO2-5000P	Infrared	Infrared	N/A	0-5000 PPM	-4 to 122 (-20 to 50)	7500 (696.7)	49 (14.9)	Mid ²
Carbon Dioxide	ICO2-5V	Infrared	Infrared	N/A	0-5% by Vol.	-4 to 122 (-20 to 50)	7500 (696.7)	49 (14.9)	Mid ²
Chlorine	CL2-5P		•	N/A	0-5 PPM	-4 to 122 (-20 to 50)	5000 (464.5)	40 (12.2)	Low ²
Chlorine Dioxide	CLO2-2P		•	N/A	0-2 PPM	-4 to 122 (-20 to 50)	5000 (464.5)	40 (12.2)	Low ²
Diborane	B2H6-2P		•	N/A	0-2 PPM	-4 to 104 (-20 to 40)	5000 (464.5)	40 (12.2)	Mid ²
Ethylene	C2H4-100L	•		2.7%	0-100% LEL	14 to 122 (-10 to 50)	5000 (464.5)	40 (12.2)	Mid ²
Ethylene Oxide	ETO-20P		•	N/A	0-20 PPM	-4 to 122 (-20 to 50)	5000 (464.5)	40 (12.2)	Low ²
Germane	GEH4-2P		•	N/A	0-2 PPM	-4 to 104 (-20 to 40)	5000 (464.5)	40 (12.2)	Low ²
Hydrogen	H2-1000P		•	N/A	0-1000 PPM	-4 to 122 (-20 to 50)	7500 (696.7)	49 (14.9)	High ²
Hydrogen	H2-2000P		•	N/A	0-2000 PPM	-4 to 122 (-20 to 50)	7500 (696.7)	49 (14.9)	High ²
Hydrogen	H2-100L	•		4.0%	0-100% LEL	14 to 122 (-10 to 50)	7500 (696.7)	49 (14.9)	High ²
Hydrogen Bromide	HBR-30P		•	N/A	0-30 PPM	-4 to 104 (-20 to 40)	5000 (464.5)	40 (12.2)	Low ²
Hydrogen Chloride	HCL-30P		•	N/A	0-30 PPM	-4 to 122 (-20 to 50)	5000 (464.5)	40 (12.2)	Mid ²
Hydrogen Cyanide	HCN-50P		•	N/A	0-50 PPM	-4 to 122 (-20 to 50)	5000 (464.5)	40 (12.2)	Mid ²
Hydrogen Sulphide	H2S-25P		•	N/A	0-25 PPM	-4 to 122 (-20 to 50)	5000 (464.5)	40 (12.2)	Low ²
Hydrogen Sulphide	H2S-100P		•	N/A	0-100 PPM	14 to 122 (-10 to 50)	5000 (464.5)	40 (12.2)	Low ²
Methane	CH4-100L	•		5.0%	0-100% LEL	14 to 122 (-10 to 50)	7500 (696.7)	49 (14.9)	High ²
Methane	ICH4-100L	Infrared	Infrared	5.0%	0-100% LEL	-4 to 122 (-20 to 50)	7500 (696.7)	49 (14.9)	High ²
Methane	ICH4-100V	Infrared	Infrared	5.0%	0-100% by Vol.	-4 to 122 (-20 to 50)	7500 (696.7)	49 (14.9)	High ²
Methanol	CH3OH-100L	•		6.7%	0-100% LEL	14 to 122 (-10 to 50)	5000 (464.5)	40 (12.2)	Low ²
Nitric Oxide	NO-100P		•	N/A	0-100 PPM	-4 to 122 (-20 to 50)	7500 (696.7)	49 (14.9)	Mid ²
Nitrogen Dioxide	NO2-10P		•	N/A	0-10 PPM	-4 to 122 (-20 to 50)	7500 (696.7)	49 (14.9)	Low ²
Oxygen ³	O2-25V		•	N/A	0-25% by Vol	-22 to 122 (-30 to 50)	7500 (696.7)	49 (14.9)	Mid ²
Ozone	O3-1P		•	N/A	0-1 PPM	-4 to 122 (-20 to 50)	5000 (464.5)	40 (12.2)	High ²
Iso-Pentane	C5H12-100L	•		1.4%	0-100% LEL	14 to 122 (-10 to 50)	5000 (464.5)	40 (12.2)	Low ²
Phosphine	PH3-1P		•	N/A	0-1 PPM	-4 to 104 (-20 to 40)	5000 (464.5)	40 (12.2)	Low ²
Phosphine	PH3-5P		•	N/A	0-5 PPM	-4 to 104 (-20 to 40)	5000 (464.5)	40 (12.2)	Low ²
Propane	C3H8-100L	•		2.1%	0-100% LEL	14 to 122 (-10 to 50)	7500 (696.7)	49 (14.9)	Low ²
Silane	SiH4-50P		•	N/A	0-50 PPM	-4 to 104 (-20 to 40)	5000 (464.5)	40 (12.2)	Mid ²
Sulphur Dioxide	SO2-6P		•	N/A	0-6 PPM	-4 to 122 (-20 to 50)	5000 (464.5)	40 (12.2)	Low ²
Combustibles ¹	GENL-100L	•		Specify Gas	0-100% LEL	-40 to 122 (-40 to 50)	5000 (464.5)	40 (12.2)	Gas

Acetaldehyde, Benzene, Carbon Disulfide, Dioxane, Ethane, Ethanol, Ethylbenzene, Gasoline, Heptane, Hexane, Ipa, Jet Fuel, Kerosene, Naphtha, Styrene, Toluene, Voc's, Xylenes, Acetylene, Diesel, Pentane, Ethyl Acetate, Propylene

Note 1: Lower Explosive Limit (LEL) | **Note 2:** Low = 0.5 to 1.5' (0.15 to 0.46m) above floor | Mid = 4.0 to 6.0' (1.20 to 1.83m) above floor | High = 0.5 to 1.5' (0.15 to 0.46m) below ceiling | **Note 3:** Oxygen sensors monitor oxygen depletion caused by numerous gases including: Nitrous Oxide, Helium, Nitrogen, Sulfur hexafluoride, Argon, Xenon, Neon.



RoHS COMPLIANT



CUSTOM ORDERING		Model # Example: B8 CO-250P O X	MODEL #
		<small>A. B. C. D. E.</small>	
A. Sensor Series <i>Select One (1)</i>	Q8 = Toxic/Combustible Gas Transmitter Series with Analog/Relay/Communicating Output Signals and Display B8 = Toxic/Combustible MS/TP BACnet™ Gas Detection Transmitter with Relays and LCD Display		
B. Gas Span Code	Enter a "Gas Span Code" from the Sensor Selection & Specification Table		
C. Enclosure <i>Select One (1)</i>	O = Standard Wall Mount Enclosure R = Remote Mount Sensor		
D. Revision <i>No Selection Required</i>	X = Factory Provided →		X
E. For GENL Sensors	Enter a "Gas Span Code" from the Sensor Selection & Specification Table (See Combustibles)		

ACCESSORIES ORDERING		
Model #	Item #	Description
GAS CAL KIT	148426	Cal Kit includes Carry Case, 0.5lpm regulator, C10 to CGA-600 adapter and tubing
79030-103	126566	Q8 Combustible Calibration Adapter
6395-0003	126254	Q8 Toxic calibration Adapter/Splash Guard
28030-012-000	150947	Q8 Combustible Splash Guard

Note: See GAS CAL KIT Data Sheet if required

ACCESSORIES ORDERING HORN STROBE		
Model #	Item #	Description
FSIG-SLM500A	136476	Streamline Horn and Strobe (Amber)
FSIG-SLM500B	142976	Streamline Horn and Strobe (Blue)
FSIG-SLM500C	150028	Streamline Horn and Strobe (Clear)
FSIG-SLM500G	143013	Streamline Horn and Strobe (Green)
FSIG-SLM500R	143132	Streamline Horn and Strobe (Red)

ACCESSORIES ORDERING MOUNTING BASE		
Model #	Item #	Description
FSIG-SLMBD-012-024GY	142977	Deep Base for FSIG-SLM500 Series; Gray
FSIG-SLMBW-012-024GY	136477	Wall Mount Base for FSIG-SLM500 Series; Gray

Note: See Strobe & Alarm Data Sheet if required

