

LENGTH OPTIONS	TOLERANCE
10'	+/- 6"
20'	+/- 6"
40'	+/- 6"

DIMENSIONS ARE IN INCHES
 TOLERANCES: (UNLESS NOTED)
 3 PLACE DECIMAL = ±0.010
 2 PLACE DECIMAL = ±0.010
 1 PLACE DECIMAL = ±0.050
 DIMENSIONS IN INCHES
 DRAWING NOT TO SCALE

DEBURR AND BREAK
 SHARP EDGES

MATERIAL:

PROPRIETARY AND CONFIDENTIAL
 THE INFORMATION CONTAINED IN THIS
 DRAWING IS THE SOLE PROPERTY OF
 AUTOMATION COMPONENTS INC. ANY
 REPRODUCTION IN PART OR AS A WHOLE
 WITHOUT THE WRITTEN PERMISSION OF
 AUTOMATION COMPONENTS INC. IS
 PROHIBITED.



DESCRIPTION:
WPR2 LCD Metal Clad

DWG. NO.
M0000662

REV
1

DATE:
8/4/2021

DRAWN BY:
 TEQ

APPROVED BY:

SCALE: 1:4

DO NOT SCALE DRAWING SHEET 1 OF 2

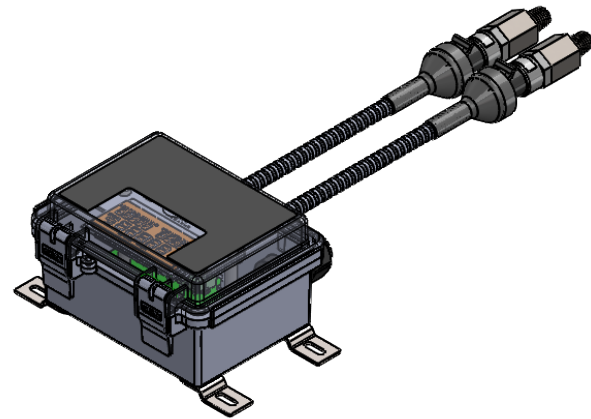
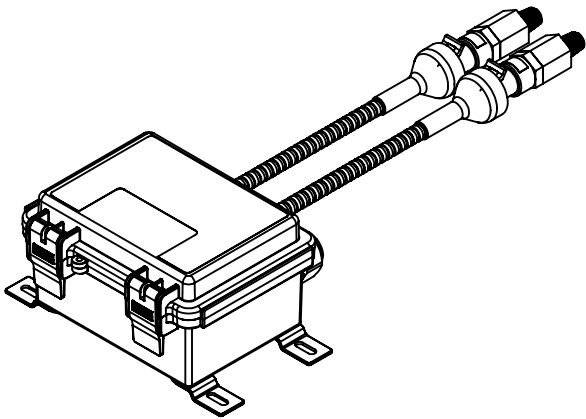

DIMENSIONS ARE IN INCHES
 TOLERANCES: (UNLESS NOTED)
 3 PLACE DECIMAL = ± 0.005
 2 PLACE DECIMAL = ± 0.015
 1 PLACE DECIMAL = ± 0.050
 DIMENSIONS IN INCHES
 DRAWING NOT TO SCALE

PROPRIETARY AND CONFIDENTIAL
 THE INFORMATION CONTAINED IN THIS
 DRAWING IS THE SOLE PROPERTY OF
 AUTOMATION COMPONENTS INC.. ANY
 REPRODUCTION IN PART OR AS A WHOLE
 WITHOUT THE WRITTEN PERMISSION OF
 AUTOMATION COMPONENTS INC. IS
 PROHIBITED.



ITEM NUMBER:

DEBURR AND BREAK
 SHARP EDGES

DESCRIPTION:
WPR2 LCD Metal Clad

DWG. NO.
 M0000662

REV
 1

MATERIAL:

DATE:

DRAWN BY:

APPROVED BY:

SCALE: 1:4

DO NOT SCALE DRAWING SHEET 2 OF 2