

READ THESE INSTRUCTIONS BEFORE YOU BEGIN INSTALLATION

All ACI thermistors and RTD Room or Space temperature sensors are both non-polarity and non-position sensitive. All thermistor type room units are supplied with a two-pole terminal block and all RTD's and 592 temperature sensors will be supplied with either a two or three-pole screw terminal block. ACI Recommends the use of 18 to 20 AWG twisted pair wire or shielded cable for all sensor installations.

■ TROUBLESHOOTING

Sensor reads 0 ohms or very low
 Sensor reads infinity or very high
 Erratic readings
 No Voltage or Current Output
 No Voltage Signal Output (592-10K)

No Current Signal Output (592)

Sensor or wires are shorted together
 Sensor or wires are open
 Bad wire connections - Condensation or Moisture problem
 Check Power Supply Voltage
 Touch sensor and verify that the voltage output increases with Voltmeter from (-) to (3W) Terminal (Reading in VDC)
 Measure Current output changes from (-) to **Controllers Input Terminal** (Reading in uA)

■ WIRING DIAGRAMS

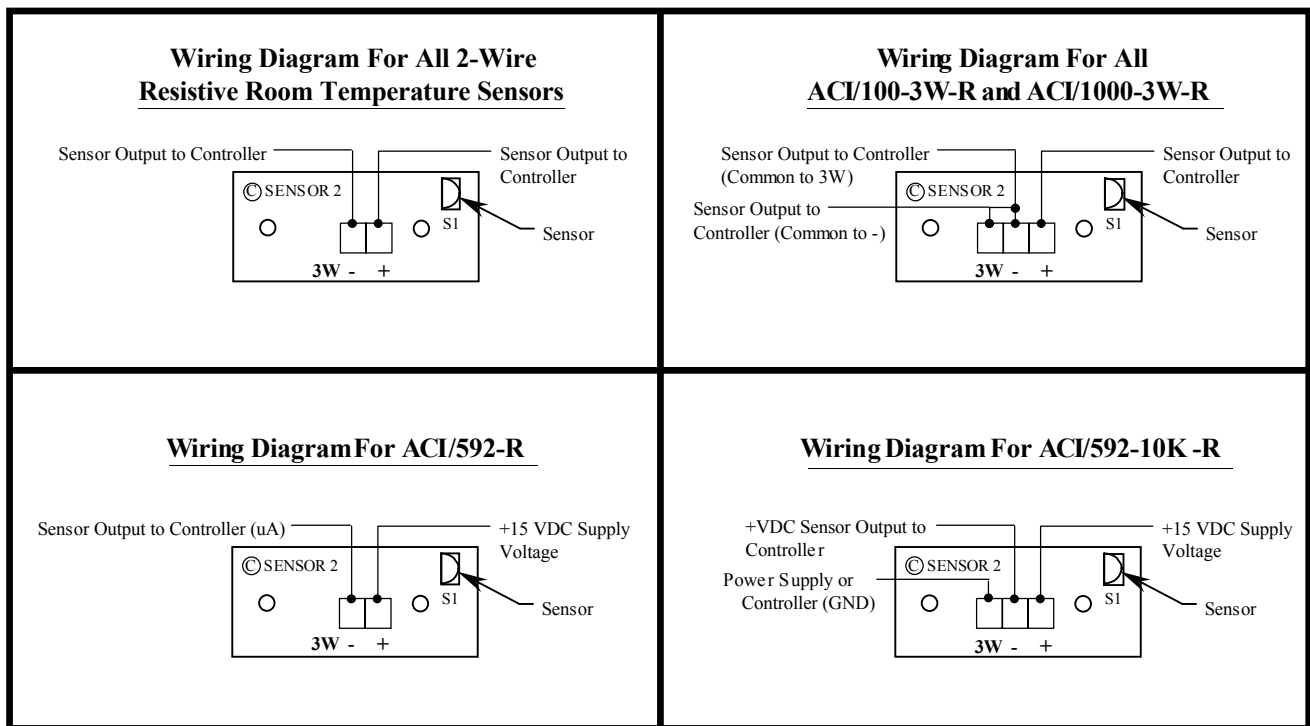

■ MOUNTING INSTRUCTIONS

This unit is suitable for either drywall mounting or junction box mounting. The room sensor is provided with screw terminal blocks for all connections. Remove the cover from the unit and mount the housing base to the wall using the (2) 6/32" x 1" Machine screws. Replace the cover and tighten down, using the (2) 1/16" Allen screws located in the lower right and left hand corners of the enclosure.

■ ROOM TEMPERATURE SENSORS

This unit is suitable for either drywall mounting or junction box mounting. The room sensor is provided with screw terminal blocks for all connections. Remove the cover from the unit and mount the housing base to the wall using the (2) 6/32" x 1" machine screws. Replace the cover and tighten down, using the (2) 1/16" Allen Screws located on the bottom of the enclosure.

■ DUCT AND DUCT AVERAGING SENSORS

Duct temperature sensors - drill a 3/8" hole in the duct and insert the probe through the hole until the foam pad is tight to the duct. Now insert (2) screws through the mounting holes in flange and tighten them until the unit is held firmly to the duct.

Duct Averaging sensors - Drill a 3/8" hole in the duct and insert the averaging element through the hole until the foam pad is tight to the duct. Now insert the (2) screws through the holes in the mounting flange and tighten until the unit is held firmly to the duct. The sensor should then be strung in a criss-cross pattern throughout the duct (see Figure #2) using the mounting clips provided, in a pattern that covers the greatest surface area of the duct, to insure that there is no stratification. When bending the copper tubing, be careful that you use a gradual bend and that you DO NOT kink the copper tubing.

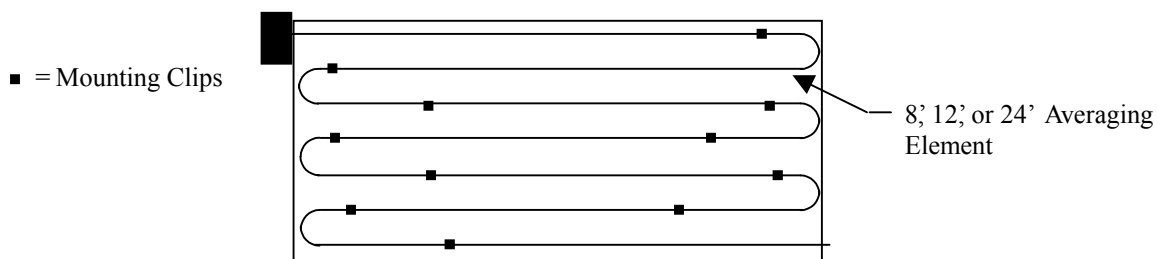

Figure #2

■ FLUID IMMERSION TEMPERATURE SENSORS

The ACI Fluid Immersion-type sensors are provided with a 2 1/2", 4", or 6 1/4" insertion length, 304 series stainless steel thermowell. The thermowell has a 1/2" NPT external or process thread and a 1/2" NPT internal or instrument thread. Heat transfer compound may be used but it is not necessary.

■ STRAP-ON TEMPERATURE SENSORS

The ACI Strap-On sensors, are provided in a NEMA 1 rated junction box with an adjustable 2" to 5" pipe clamp. The unit should be mounted on the bottom side of the pipe to ensure proper heat transfer and a true temperature reading. Heat transfer compound and insulating the sensor will help the overall accuracy of the sensor. By ordering extra straps, and fastening them together, it is possible to make them fit larger pipes.

■ OUTSIDE AIR TEMPERATURE SENSORS

The ACI Outdoor Air temperature sensors are provided in a weatherproof enclosure. An optional weatherproof Aluminum Bell Box or NEMA 4X Polycarbonate enclosure is also available upon request for an additional charge. All of the mounting hardware is provided with the sensor. Be sure to mount the sensor out of direct sunlight, with the sensor probe pointing downward.

■ STAINLESS PLATE TEMPERATURE SENSORS

The ACI Stainless Plate temperature sensors are mounted on the back of a 1 Gang stainless steel plate. The foam pad will insulate the sensor from any drafts in the wall. (2) 6/32" x 1" machine screws are provided for junction box mounting. Be sure that the sensor is not mounted on an outside wall, due to the extreme temperature changes from either drafts or heat transfer.